

LOC		DIST		REVISIONS			
CM	00	REV	LTR	DESCRIPTION	DATE	OWN	APVD
		N		REVISED PER DG38-1100-04	12OCT05	KW	SR

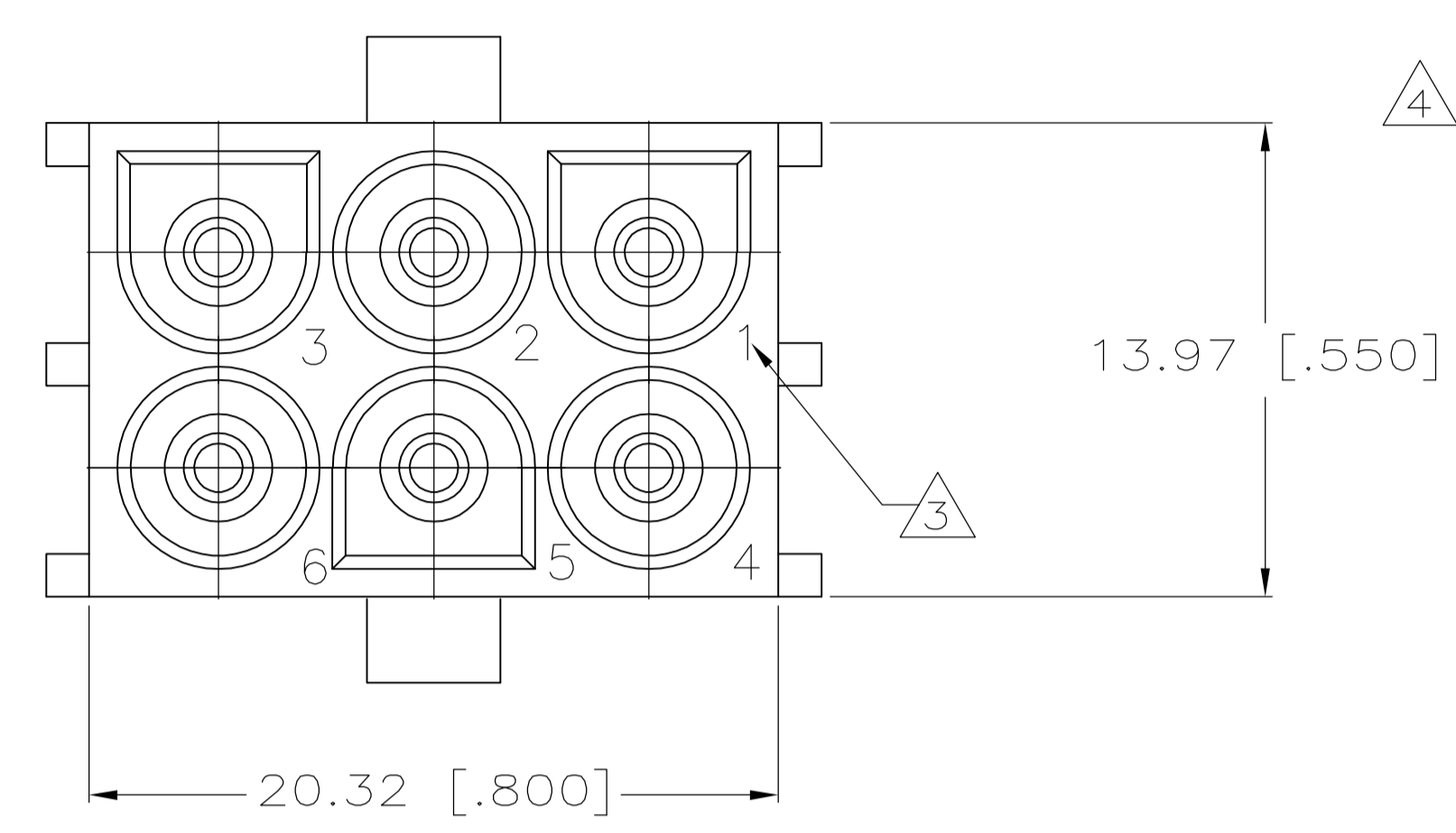

1. PARTS MUST COMPLY WITH AMP SOLDERABILITY SPEC 109-11-3.
2. CONTACT IS STAMPED FROM PRE-PLATED STOCK WHICH IS PLATED OVERALL WITH 0.00127 [.000050] NICKEL, THEN STRIPED WITH 0.00076 [.000030] GOLD IN CONTACT AREA INDICATED AND TIN-LEAD ON SOLDER TAIL END.
3. CIRCUIT IDENTIFICATION CHARACTERS ARE ADJACENT TO THE INDICATED CAVITIES, BUT LOCATION AND ORIENTATION MAY DIFFER FROM PRINT.
4. CONTACT IS PLATED OVERALL WITH 0.00127 [.000050] NICKEL, THEN 0.00076 [.000030] GOLD OVER CONTACT LENGTH INDICATED AND MATTE TIN ON SOLDER TAIL END.

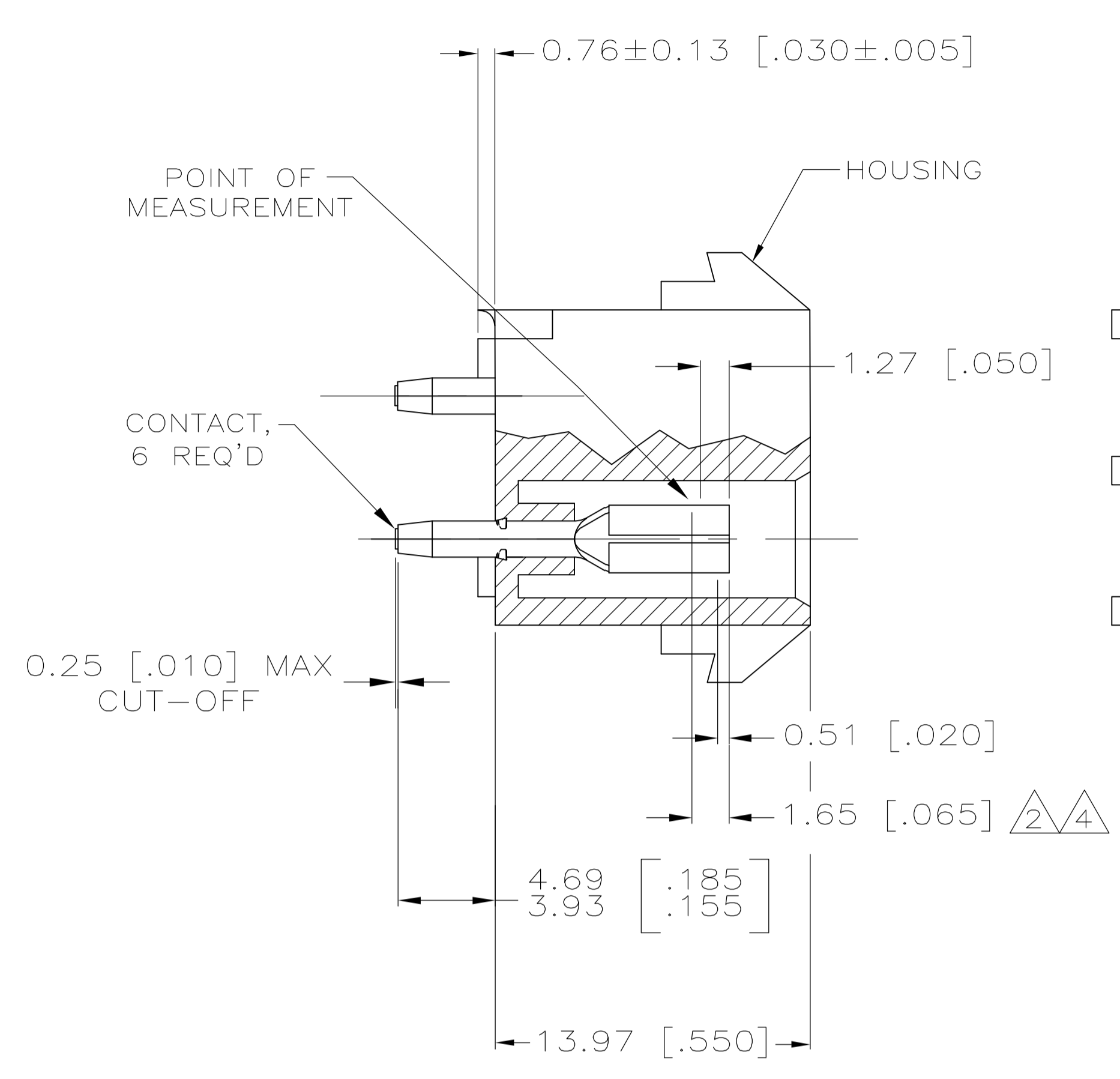
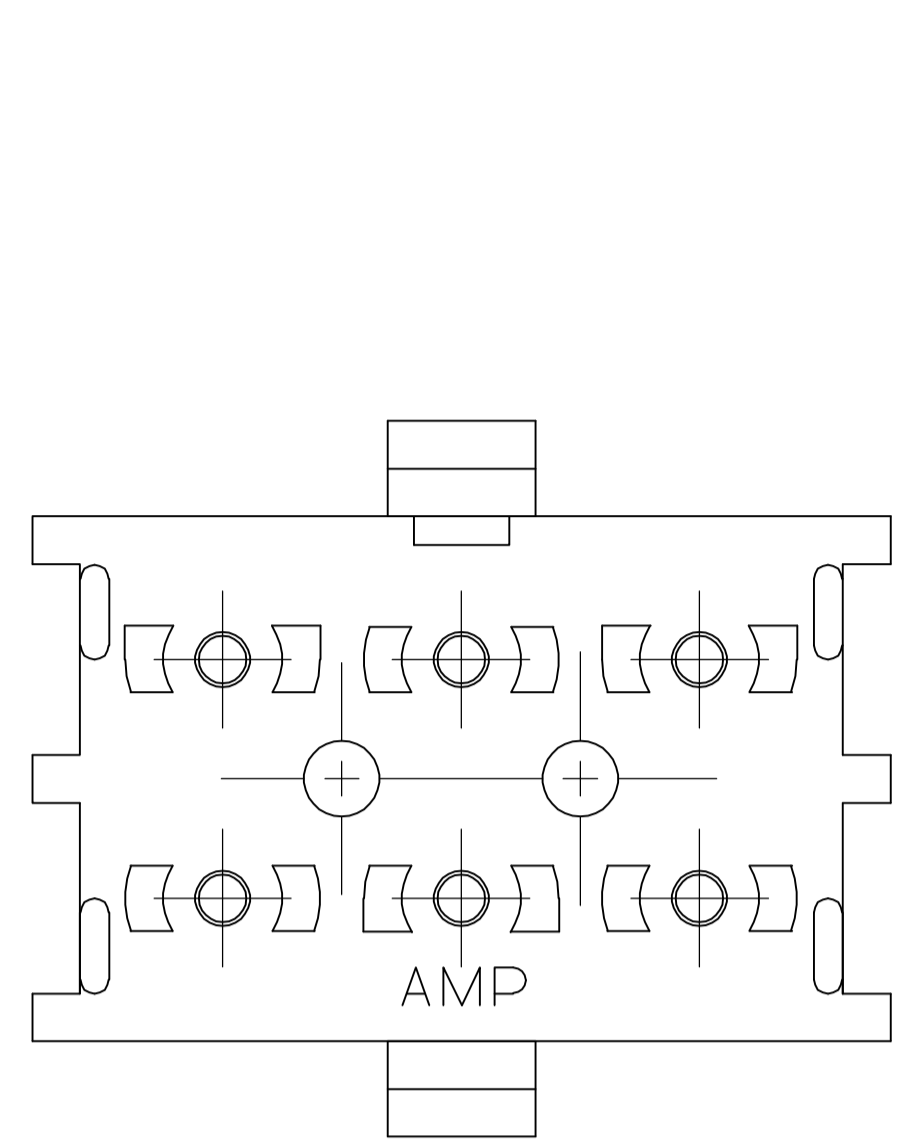
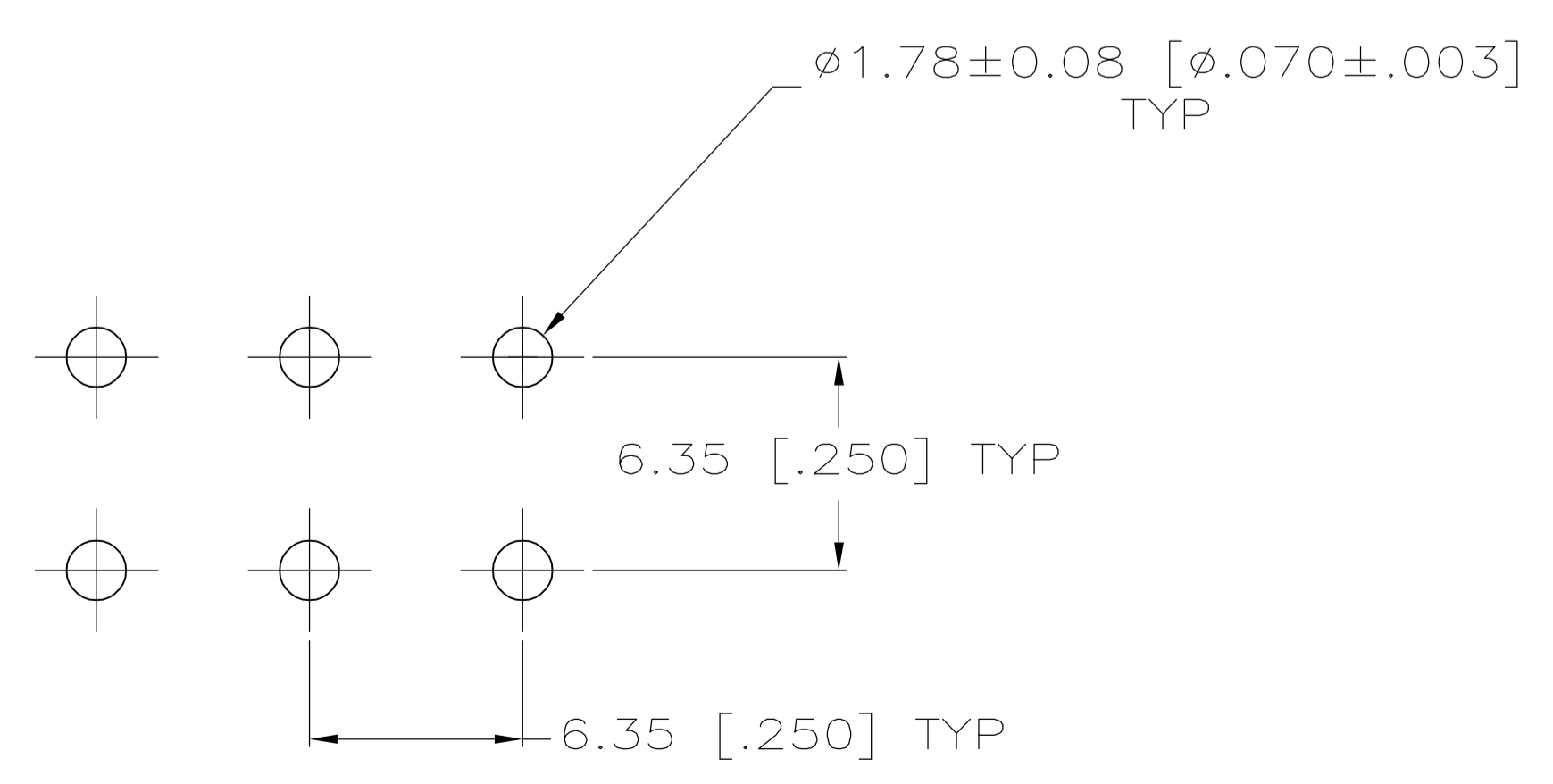

RECOMMENDED LAYOUT FOR 1.58 [.062] THICK PC BOARD

PH BRZ GOLD 4	NYLON, NATURAL	350762-5
PH BRZ TIN	NYLON, NATURAL	350762-4
PH BRZ GOLD 2	NYLON, NATURAL	350762-3
CONTACT	HOUSING	PART NO

THIS DRAWING IS A CONTROLLED DOCUMENT.

DIMENSIONS: mm (INCHES)	TOLERANCES UNLESS OTHERWISE SPECIFIED: 0 PLC ± 1 PLC ± 2 PLC ± 3 PLC ± 0.13 [.005] 4 PLC ± ANGLES ± FINISH	OWN: K. WHITAKER 11OCT2005 CHK: S. RIDGILL 11OCT2005 APVD: S. RIDGILL 11OCT2005	NAME: 6 CIRCUIT UNIVERSAL MATE-N-LOK (TM) P.C. BOARD SOCKET HEADER ASSEMBLY
MATERIAL: SEE TABLE	FINISH: SEE TABLE	SIZE: A1 CAGE CODE: 00779 DRAWING NO: 350762	RESTRICTED TO: CUSTOMER DRAWING

SCALE: 5:1 SHEET 1 OF 1 REV N

